

# ZebraTech

## Moana Temperature and Pressure Sensor

### Moana Deck Unit

Technical and Operation Manual V2.2

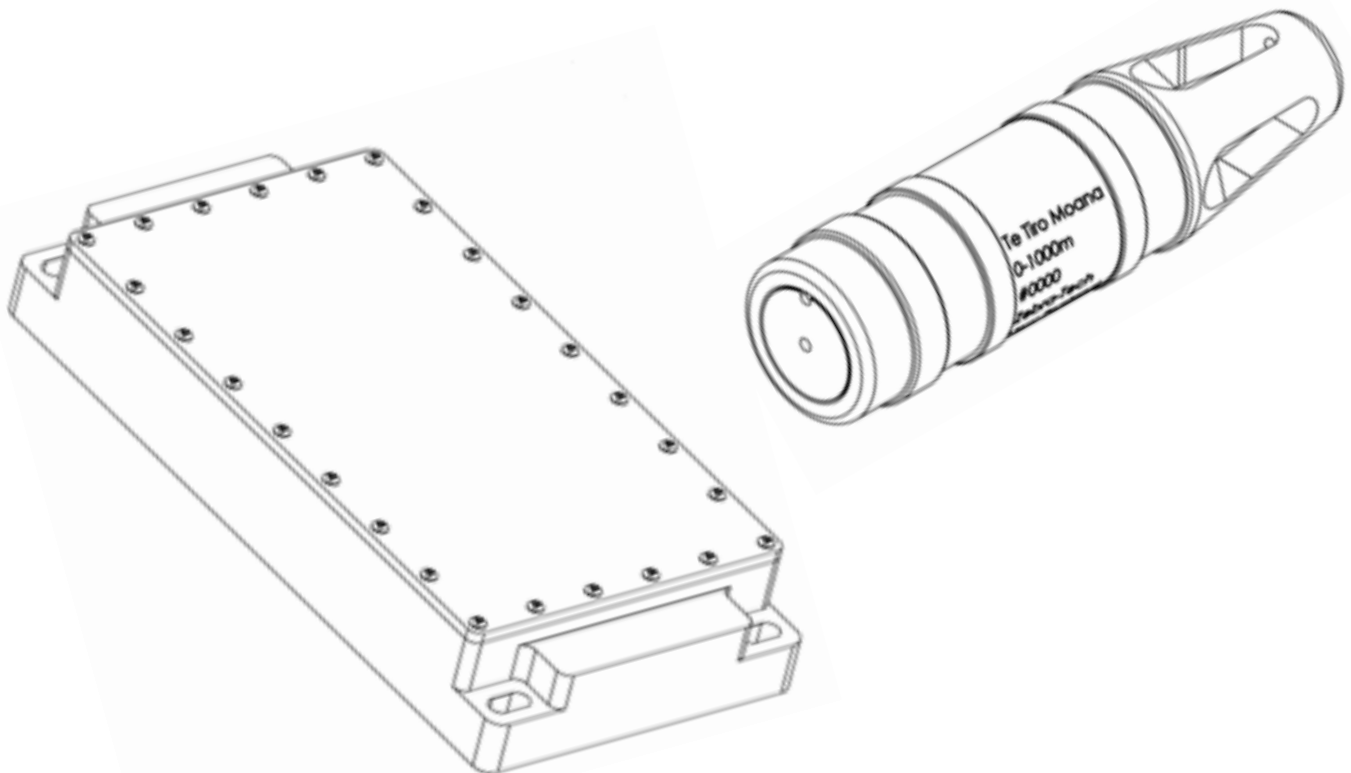

## Contents

Introduction .....	4
Moana TD.....	5
Physical Description .....	5
Moana TD Specifications.....	7
Moana TD.....	8
Functional Overview .....	8
Mounting.....	9
Long lining and hand line casting.....	9
Fishing pots .....	11
General purpose mount.....	12
Trawling.....	13
Netting .....	15
Purse sein.....	15
Moana TD2000 attachment.....	17
Deck Unit.....	18
Overview .....	18
Version overview .....	20
Standard Deck Unit .....	20
External Power Deck Unit .....	20
Moon pool.....	20
Turning the Deck Unit on and off.....	20
Installation .....	21
Deck Unit to Moana TD communication.....	21
GPS reception.....	21
Solar generation.....	22
Cellular and Wi-Fi signal strength .....	22
Safe location.....	22
Operating temperature.....	23
Hardware considerations.....	23
Example mounting locations.....	24

.....	25
.....	25
Operating in hot climates.....	26
Deck unit angle mounting.....	26
Heat Shield.....	27
Heat Shield Kit.....	28
Installation.....	28
Deck Unit Specifications.....	30
Revisions.....	31
Hardware revisions.....	31
Firmware revisions.....	31
Cellular setup.....	32
SIM card slot.....	32
1) Clear rectangular cover plate.....	32
Removal.....	32
Re-install.....	32
SIM install.....	33
Hologram SIM setup.....	34
Non-Hologram SIM setup.....	34
APN setting.....	34
Cellular Setup Trouble shooting.....	36
Wi-Fi setup.....	37
Setting Wi-Fi credentials.....	37
Wi-Fi Trouble shooting.....	38
Starlink Maritime Wi-Fi.....	39
Cell/Wi-Fi priority system.....	40
Setup.....	40
Deck Unit status LED.....	41
GPS LED indicator.....	41
Battery LED indicator table.....	42
USB charging port.....	43
Tracking Function.....	43
Port Mode.....	44
Thermal responsive charging control.....	46

Low temperature charging control .....	47
Data Format .....	48
Data delivery .....	49
External power version .....	50
USB power bank.....	50
External power supply .....	51
Connector specifications.....	51
Status LED .....	51
Moonpool version.....	52
GPS data.....	53
Power supply.....	53
Connector.....	53
Status LED .....	53
Dashboard.....	54
ZebraTech BLE app.....	55
Maintenance and calibration.....	56
Further Assistance.....	57

# Introduction

The Moana TD sensor is a fully autonomous, self-contained and robust submersible instrument for recording temperature and pressure.

The Deck Unit is a device that automatically offloads Moana TD, processes the data and then uploads it to secure cloud storage.

The Moana TD and Deck Unit combination has been developed and optimised for deployment on commercial fishing vessels. Installation is quick and simple. Once installed, the system has minimal impact on the on-board workflow during the fishing operation yet generates and reports vital subsurface data.

The Moana TD is very rugged and designed to withstand the harsh operating environment associated with commercial fishing. A range of mounting hardware is available from ZebraTech that facilitates quick and simple user installation on fishing gear, whilst providing additional protection from physical impacts.

The instrument has a fast-responding temperature sensor for accurate water column profiling. The temperature sampling regime adapts to the deployed conditions, switching automatically between profiling mode in dynamic conditions (such as a trawl net) and time series mode in static conditions (such as a fishing pot).

The Deck Unit is a self-contained solar powered device that is simple to install and requires no user intervention for operation.

When a Moana TD is lifted out of the water, the Deck Unit wirelessly detects it and data is automatically offloaded. The Deck Unit then processes and delivers the data to the secure cloud server, through the vessels Wi-Fi network or cellular network.

The Moana TD and Deck Unit combination provide a reliable, cost effective and simple to install method of accurately monitoring sub surface sea temperatures.

# Moana TD

## Physical Description

The Moana TD sensor is currently available in 3 models: Moana TD200, Moana TD1000 and Moana TD2000. Moana TD200 and TD1000 are physically identical except the pressure sensor depth ratings, which have a maximum operating depth of 200m and 1000m respectively. Moana TD2000 is physically larger, with a 2000m maximum operating depth.

The Moana TD sensor consists of a tough plastic water-tight housing. The fast-responding temperature sensor is mounted on one end inside a protective guard and the pressure sensor on the opposing end.

The pressure sensor cavity is filled with a proprietary wash-out resistant copper impregnated gel. This deters debris and organisms from dwelling within the cavity and prevents ice developing in the cavity during freezing conditions.

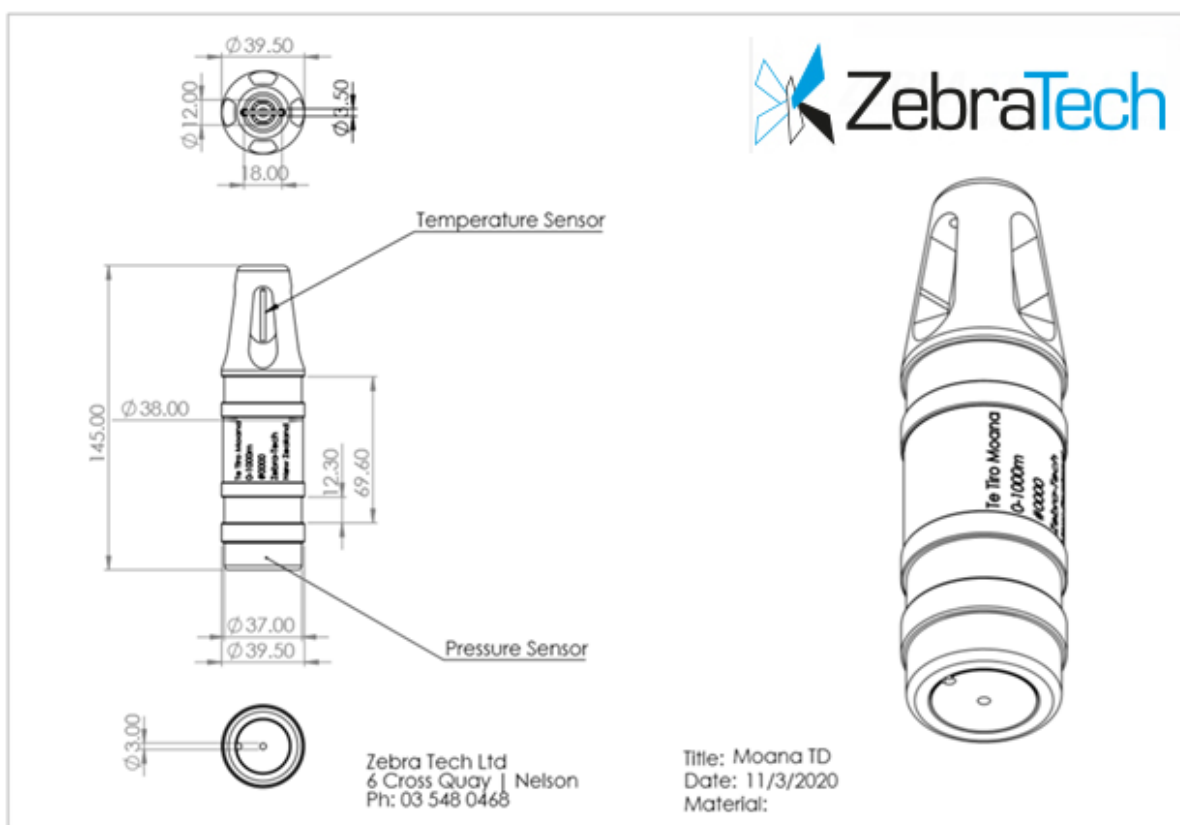

*Moana TD200 and Moana TD1000 dimensions*

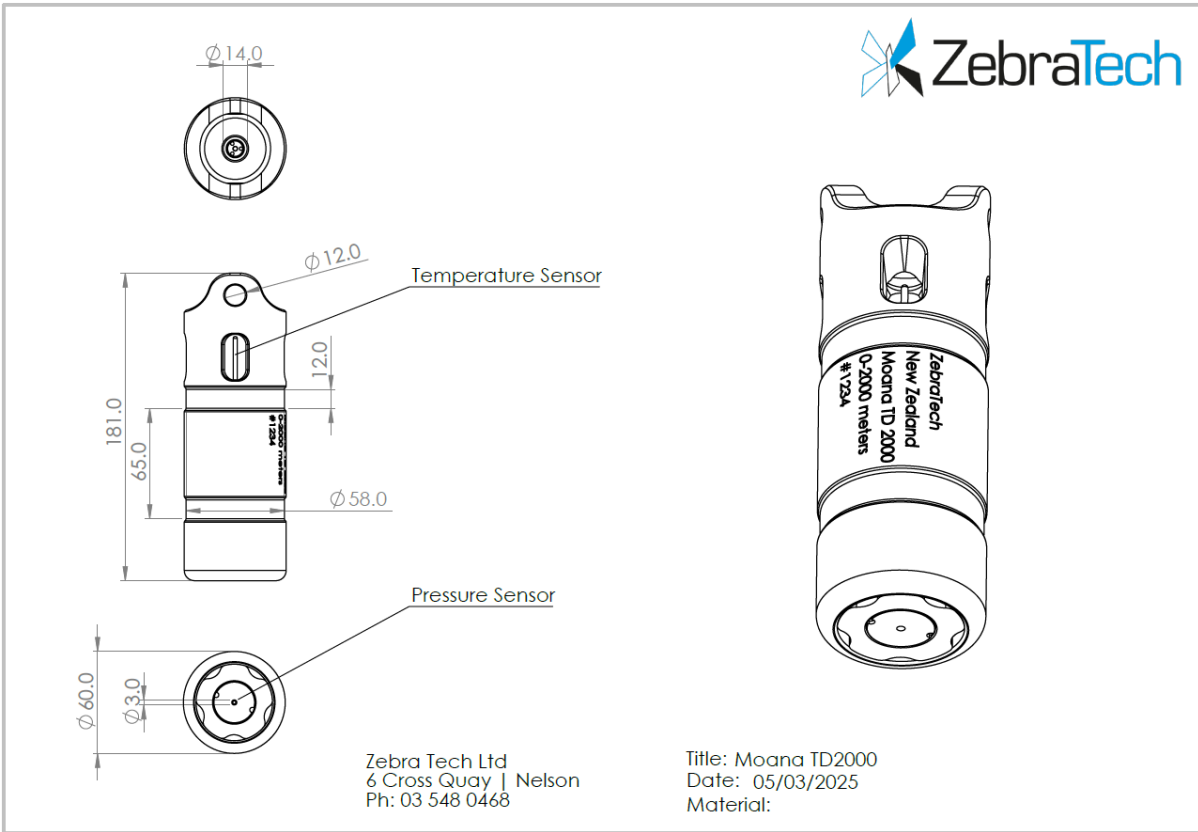

Moana TD2000

## Moana TD Specifications

<b>Physical</b>	<p><b>Moana TD200 and TD1000</b> 145mm long x 39.5mm diameter Dry weight: 185g Wet weight: 39g</p> <p><b>Moana TD2000</b> 181mm long x 60mm diameter Dry weight: 583g Wet weight: 157g</p>
Housing material	Acetal
Thermistor thimble	Titanium
<b>Temperature</b>	
Operating range	Standard calibration 3 DegC to 36 DegC Subzero and custom calibration range available on request
Initial accuracy	+/- 0.05 DegC or better
Resolution	0.001 DegC
Response rate	1 second time constant
<b>Pressure</b>	
Calibrated range	
Moana TD200	0 to 200m
Moana TD1000	0 to 1000m
Moana TD2000	0 to 2000m
Initial accuracy	+/- 0.5% of full-scale temperature compensated
Resolution	0.1m
<b>Memory</b>	
Data storage	Non-volatile
Capacity	31,146 records (1 record = time, date, depth, temperature)
<b>Battery</b>	
Type	Lithium Thionyl Chloride
Replacement	Factory replacement only
Life expectancy	2 years minimum
<b>Communications</b>	
Type	Bluetooth Low Energy 4
Range	30 meters line of sight

# Moana TD

## Functional Overview

Moana TD is a fully automatic instrument, requiring no user intervention. To ensure reliable long-term operation in an unpredictable and harsh range of operating conditions, Moana TD undertakes a variety of robust on-board data processing algorithms to determine sampling strategy.

In air, Moana TD routinely analyses atmospheric pressure measurements to maintain a baseline of the current ambient sea level pressure.

Specific pressure changes relative to the baseline pressure trigger the start of a dive. The sea level baseline enables Moana TD to reliably detect the start of an immersion event within a relatively small depth change, despite changing atmospheric pressure, thermal shifts, splash conditions, and long-term sensor drift.

During the dive state, Moana TD200 and Moana TD1000 records depth and temperature at every 1m depth change (Moana TD2000 records every 2m depth change), down to a depth of 200m. At depths greater than 200m, Moana records at every 4m of depth change.

If the depth does not change by more than 1m between the surface and 200m deep, or by more than 4m deeper than 200m, then time series temperature and depth measurements are recorded every 5 minutes.

Moana TD operates a depth dependent real-time wave filtering algorithm between the surface and 35m water depth. This reduces unnecessary recordings of measurements that are triggered by wave induced pressure changes.

When Moana TD emerges from the water and the dive terminated, and the Moana TD starts advertising over Bluetooth. A ZebraTech Deck Unit in proximity will be permitted to connect and offload all the data on the Moana TD quickly and autonomously.

If an offload event doesn't occur after 24 hours, the Bluetooth will remain active but will reduce advertising frequency to 30 seconds. After 72 hours, the Bluetooth is shutdown to conserve battery power, and the Moana TD enters a sleep state.

If Moana TD starts a new dive event without the previous data being offloaded, the data is still retained and will be offloaded in the next successful offload.

After the data has been successfully offloaded, the data on Moana is internally deleted and cannot be retrieved.

## Mounting

A variety of mounting hardware has been developed by ZebraTech, to facilitate simple attachment of Moana TD200 and Moana TD1000 to a range of fishing gear. ZebraTech is constantly developing new mounting hardware to suit different fishing gear. A selection of mounting options is presented below, but please do not hesitate to contact ZebraTech to discuss your specific requirements.

**Please note, hose clamps or U bolts applied directly onto the Moana TD housing can cause distortion of the housing, resulting in seal failure and fatal damage.**

### Long lining and hand line casting

For low physical impact deployments, Moana TD200 and Moana TD1000 can be fitted with a tow ring, to which a line or leader can then be attached for manual casting and long lining applications.

The tow ring can be fitted to Moana TD200 and Moana TD1000 at the factory when ordered or can be supplied as a user-fit kit from ZebraTech.



*Tow ring*

Tough Jacket #4 is ideal for harsh long lining applications, providing both protection and simple line attachment.



Tough Jacket #4

Moana TD200 and Moana TD1000 can be user installed into Tough Jacket #4. Use a 2.5mm Allen key to secure the end cap with the grub screws

## Fishing pots

Moana TD200 and TD1000 can generally be secured inside fishing pots without additional protection. However, it must be firmly secured in a method that does not apply pressure to the Moana TD housing.

Stauff Clamp (Part number 538-PP-H) is a low-cost non-pinching clamp that is ideally suited for securing Moana TD200 and TD1000. It is readily available internationally from Stauff distributors or directly from ZebraTech.

ZebraTech mounting plate #2 is a stainless-steel plate that can either be welded onto a steel structure or clamped using U bolts. A Stauff clamp secures the sensor to the plate with an M6 hex socket screw.

Tools required for the Stauff clamp are 10mm spanner and 5mm Allen key

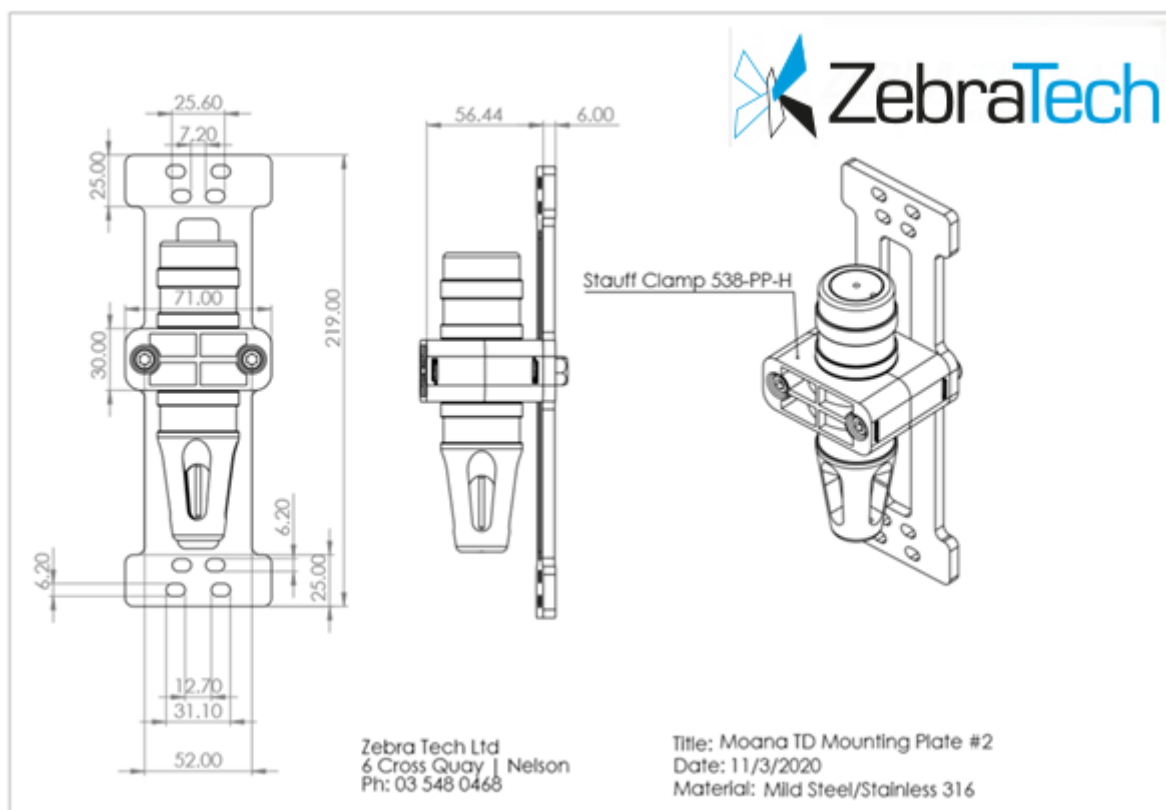

*Pot mounting plate #2*



*Moana TD mounted inside a fishing pot*

### **General purpose mount**

ZebraTech mounting plate #5 is an acetal plastic plate that can be easily drilled and bolted to support structures

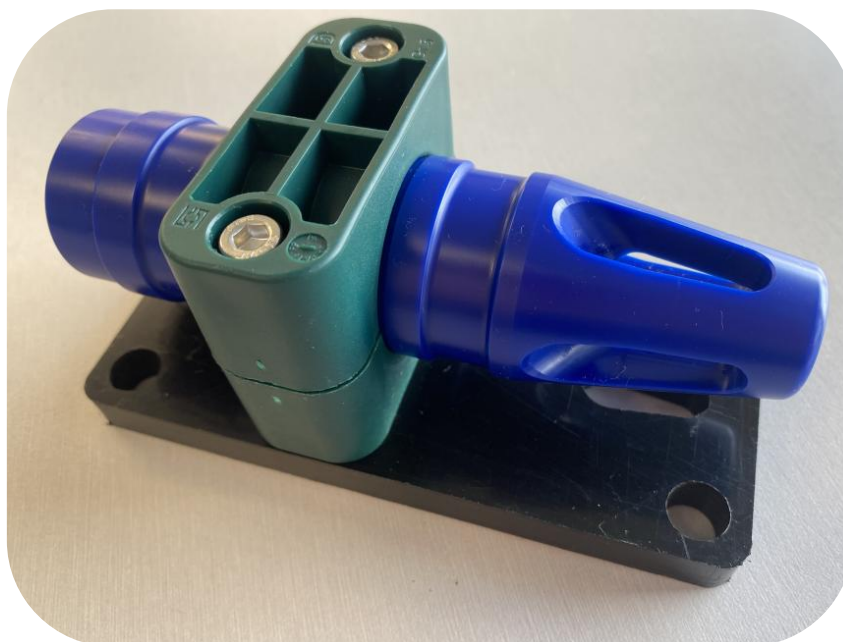

*Moana TD mounting plate #5*

## Trawling

The Moana TD200 and TD1000 can be attached to a trawl door using Tough Jacket #3 with saddle clamps. It is essential that when the trawl door is lifted out of the water, the Moana TD sensor has clear line of site with the Deck Unit. If the door is stowed on the outside of the vessel, door mounting may not be suitable.

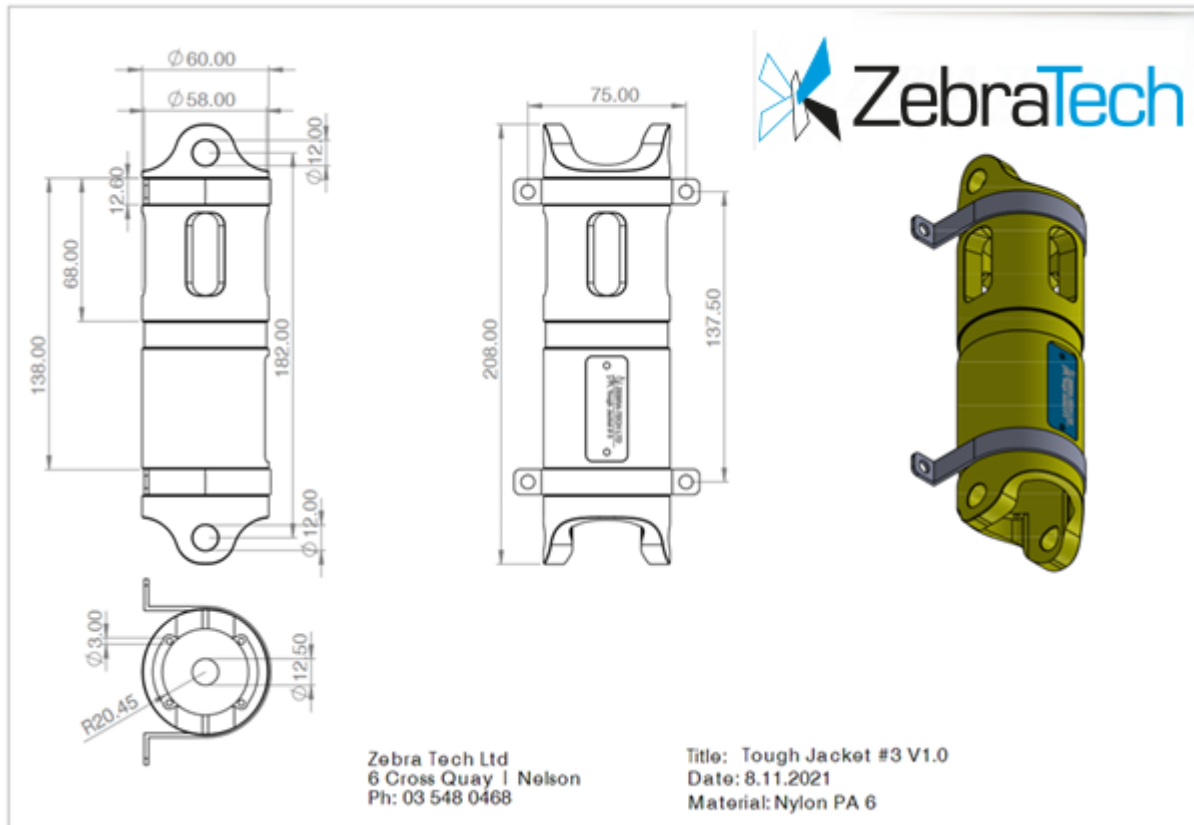

*Tough Jacket #3 with saddle clamps*



*Tough Jacket #3 on a trawl door*

Tough Jacket #3 can also be tied onto the head rope of the trawl net using the eyelets on each end for securing.



*Tough Jacket #3 rope attachment*

## Netting

Tough Jacket #3 can be tied or clipped onto nets using D shackles and sharp clips



*Tough Jacket #3 attached to a net*

## Purse sein

Tough Jacket #1 is a good choice for Purse sein net attachment, offering good impact resistance with a single attachment eyelet that avoids snares with the net.



*Tough Jacket #1 attached to a Purse sein net*

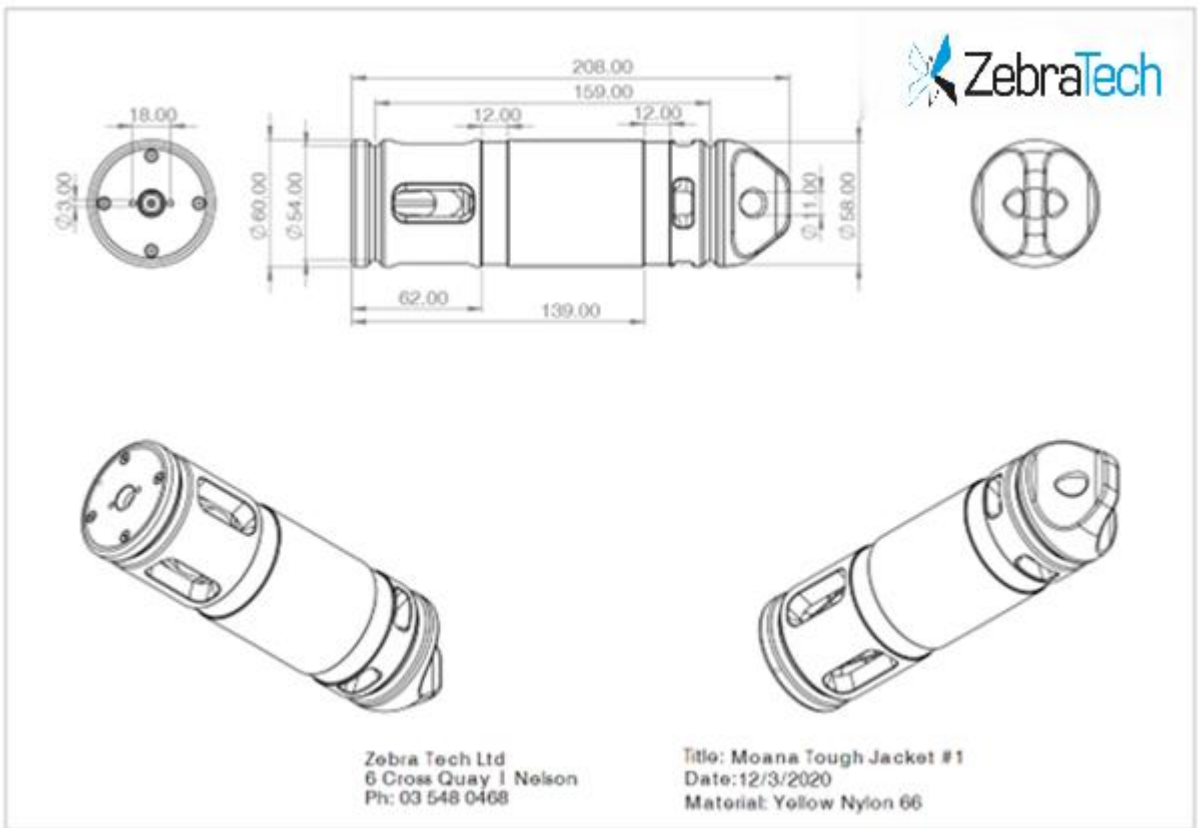

*Tough Jacket #1*

## Moana TD2000 attachment

The Moana TD2000 housing is thicker walled than the other versions, to withstand the higher operating pressures. Subsequently, the housing is sufficiently robust to not require additional protection under normal operating conditions.

The housing incorporates 2 eyelets, for securing a leader line in long lining operations.



*Moana TD2000 line attachment*

For attachment to physical structures, such as fishing pots and trawl doors, Stauff clamps can be used. It's vital that a non-pinching clamp is used, to avoid exerting pressure on the housing wall. Please contact ZebraTech to discuss mounting options for the Moana TD2000

# Deck Unit

## Overview

### Important notes

If the Deck Unit is physically damaged in any way, including moisture intrusion, do not operate the Deck Unit, and contact ZebraTech

The maximum operating temperature of the deck unit is 60DegC. The Deck unit maximum daily internal temperature, and overtemperature alarms are reported to fleet managers via the ZebraTech Dashboard. Various heat mitigation strategies exist, outlined in the “Operating in hot climates” section below. Please contact ZebraTech to discuss these if required.

The Deck Unit is a self-contained standalone communication hub. Its purpose is to automatically and wirelessly receive data from Moana TD as they are lifted on deck. The Deck Unit then process the data and uploads it to the cloud server using cellular or Wi-Fi connectivity.



*Standard Deck Unit*

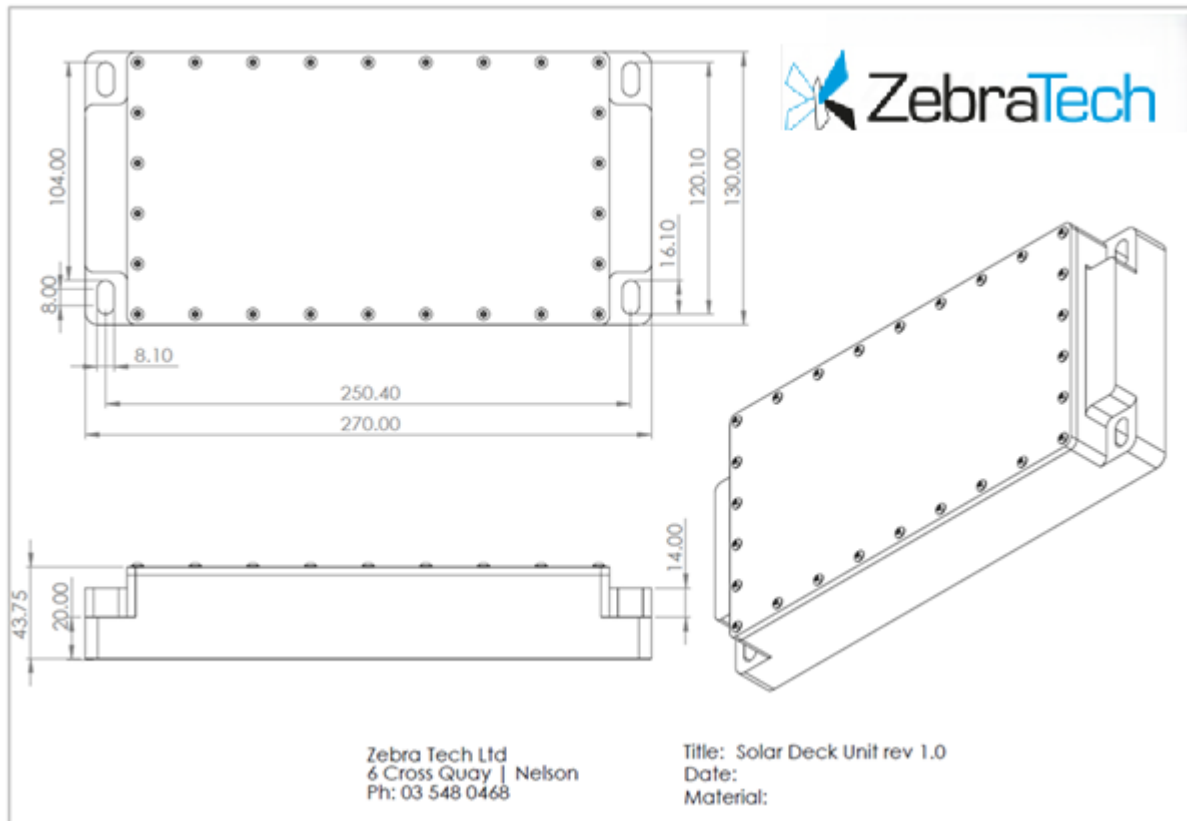

*Deck Unit dimensions*

The Deck Unit constantly monitors for any Moana TD radio transmissions. When a Moana TD is detected, the devices pair and the data transferred from the Moana TD to the Deck Unit.

The data offload process has been optimised for speed. The data from a typical deployment will be fully offloaded in less than 30 seconds from the Moana emerging from the water. The wireless range is around 30 meters line of sight. Moana TD and Deck Units are agnostic; any Deck Unit will offload any Moana TD. This avoids the need for complex pairing and instal setups.

After the data has been offloaded from the Moana TD, the Moana TD stops advertising and enters a sleep state until the start of the next dive event is detected.

The Deck Unit processes the Moana TD data file; time synchronised position data is applied to the data, extracted from the historic position log maintained by the Deck Unit.

The processed file is then uploaded to the ZebraTech cloud server, either by the cellular network or the vessel Wi-Fi network (if setup).

If the cloud server upload is unsuccessful, for example due to a lack of cellular coverage or Wi-Fi connectivity, the Deck Unit retries occur every 2 hours until a successful upload is achieved.

## Version overview

### Standard Deck Unit

The standard Deck Unit has an internal battery and solar panel, so it does not require any external vessel power making installation simple. It has Wi-Fi and cellular capability. The Deck unit has a tough weatherproof housing and once installed and operational, requires no operator input.

### External Power Deck Unit

For installations where there is inadequate natural solar energy, the external power option is a good solution. Having all the features of the standard Deck Unit, this version has an additional external connector that enables the Deck Unit to be top-up charged or continually operated from a power source.

### Moon pool

The Moonpool version of Deck Unit can be installed below deck, where solar and GPS signal are not available. It has a connector for external power, and GPS data.

## Turning the Deck Unit on and off

Switch version 1 (Serial number 5300 to 5465)  
Remove the cover plate and slide the switch to the appropriate position  
Replace the cover plate (refer to the instructions above)

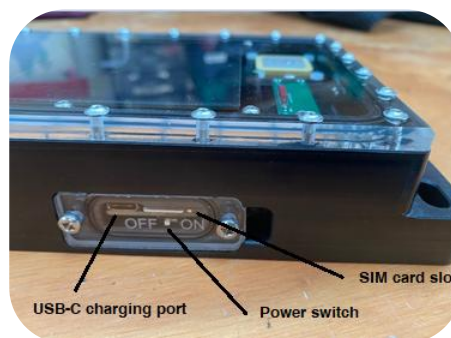

Switch version 2 (Serial number 5466 onwards)  
Rotate the switch to the appropriate position

## Installation

The mounting location of the Deck Unit needs to be carefully considered. The requirements are:

1. Within 30 meters line of sight from where the Moana TD is lifted on deck, for at least 30 seconds
2. Has a good sky view for GPS signal reception
3. Receives good sun for solar generation
4. Good Wi-Fi and/or cellular communication signal strength
5. Is in a safe location where it will not interfere with the fishing operation, or get damaged
6. Avoids excessive temperatures
7. Securely fastened to a solid structure

### Deck Unit to Moana TD communication

The wireless connection between the Moana TD and Deck Unit has been optimised for speed and reliability.

The Moana TD starts advertising within 10 seconds of being lifted out of the water. The Deck Unit is constantly scanning for advertising Moana. When the Deck Unit detects and connects to a Moana TD, the blue data LED is illuminated for the duration of the connection, whilst data is offloaded.

In open unobstructed conditions, the operating range between the Moana TD and Deck Unit can be up to 30 meters with clear line of sight. This range may be impacted by local obstructions and surrounding physical structures, however the wireless link between Moana TD and Deck Units have been well proven over hundreds of installs to be robust and very reliable.

When considering the Deck Unit location, it is highly recommended that the wireless connection is tested prior to deciding on the final location. Submerge a Moana TD to a minimum of 4 meters water depth for at least 12 seconds, then lift it onto the working deck, and observe the blue LED activity on the Deck Unit.

### GPS reception

The Deck Unit requires a consistent GPS signal to maintain the track log, that it then uses to time synchronise position stamp the Moana TD data.

The Deck Unit tracks the US GPS satellite constellation. It is important to mount the Deck Unit in a location with full or good sky view. A limited sky view will reduce the number of

visible satellites, and result in longer position fix times. This can increase the power requirements of the Deck Unit.

When installing the Deck Unit, check that the GPS LED is flashing green to indicate successful position detection.

### **Solar generation**

To avoid the need for a cabled power supply, the Deck Unit incorporates an internal rechargeable battery and solar panel.

The Deck Unit has been carefully designed to minimise power consumption. When the internal battery is fully charged, it will power the Deck Unit for around 4 weeks without any solar charge.

It is important to locate the Deck Unit where it will receive adequate solar energy to sustain its operation all year round.

### **Cellular and Wi-Fi signal strength**

Cellular signal strength may not be significantly impacted by mounting location, and generally, if the above conditions are met, then the Deck Unit should connect to a cellular network if present.

If the Deck Unit is to be used in conjunction with the vessel Wi-Fi network, it is important to locate a position where the signal strength is consistently good. This can be done using a Wi-Fi network analyser app on a mobile phone. There are several free apps available for both IOS and Android devices.

**Note that the Deck Unit will only operate on 2.4GHz Wi-Fi networks, not 5GHz.** Also ensure that the Wi-Fi network is consistent. For example, there have been instances where a vessel at port has open bulkhead doors. At sea, the doors are closed, which can reduce the Wi-Fi range, resulting in the Deck Unit losing Wi-Fi connectivity.

### **Safe location**

Although the Deck Unit is tough, it can be damaged by impacts from swinging gear. The Deck Unit should not be located where it will obstruct or cause harm to passing crew.

## Operating temperature

The maximum internal operating temperature of the Deck Unit is 60DegC. Under some circumstances, the internal temperature can exceed 60DegC in hot climates.

The Deck unit maximum daily internal temperature, and overtemperature alarms are reported to fleet managers via the ZebraTech Dashboard. Various heat mitigation strategies exist, outlined in the “Operating in hot climates” section below.

Please contact ZebraTech to discuss heat mitigation requirements and strategies

## Hardware considerations

The Deck Unit must be mounted firmly to a physical structure, that does not introduce additional vibration or impacts.

The attachment method should not introduce stress on the Deck Unit housing. If the Deck Unit is to be clamped onto a round structure such as a rail, use the optional mounting brackets available from ZebraTech. These are 316 stainless steel 1½” M8 U bolt with washers and Nyloc lock nuts



*Deck Unit with optional mounting brackets fitted*

## Example mounting locations

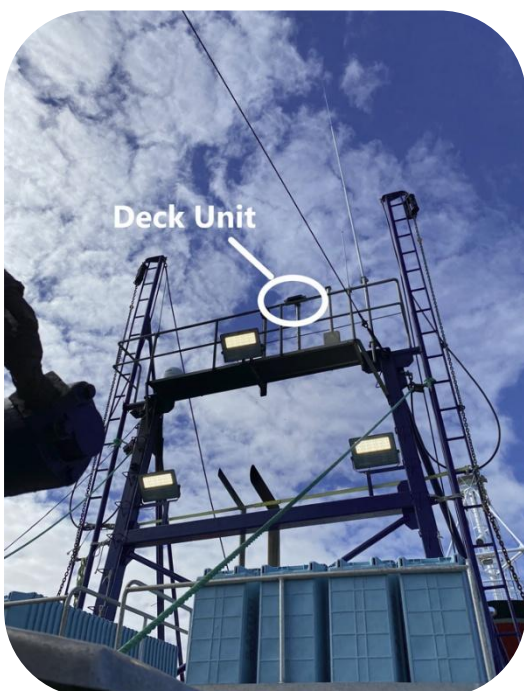

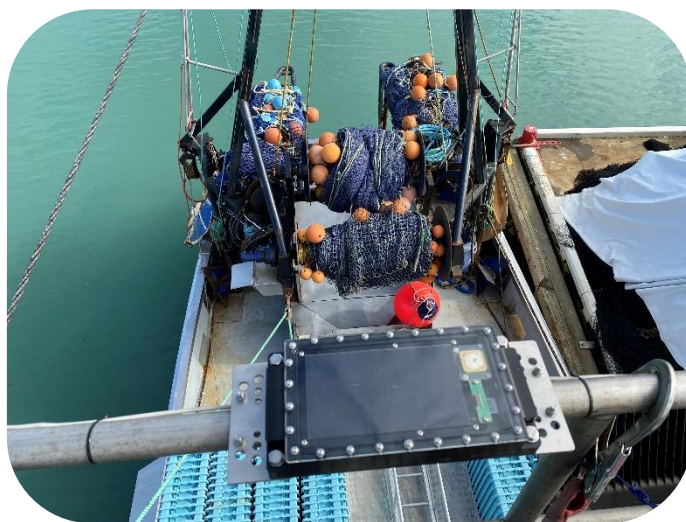
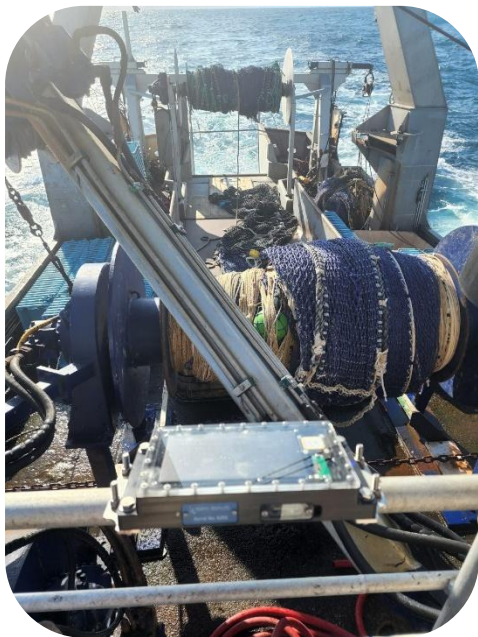
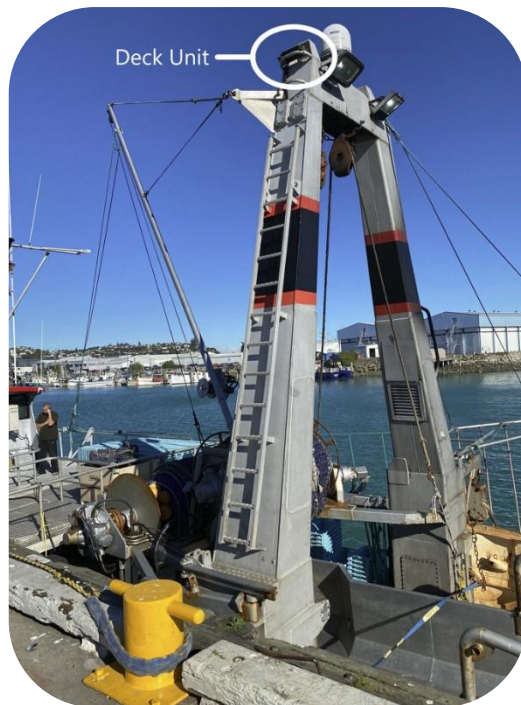

## Operating in hot climates

The Deck Unit should not exceed 60 DegC internal temperature. Temperatures above this can result in deterioration and degradation of the batteries, which may under certain circumstances be hazardous.

The maximum daily Deck Unit internal temperature is reported to fleet managers in the ZebraTech Dashboard. In addition, if the daily internal temperature exceeds 60 DegC, an alarm is raised in the fleet managers Dashboard.

It is not possible to apply broad geographical rules around location and Deck Unit internal temperature, due to the local meteorological conditions and variations in operating circumstances.

In hot climates, the fleet manager should closely monitor the Dashboard to gain local knowledge of the Deck Unit fleet and deploy the following mitigation strategies as required. Please do not hesitate to contact ZebraTech to discuss these as required

## Deck unit angle mounting

Mounting the Deck Unit at an angle from horizontal, can be an effective method to reduce thermal accumulation. The greater the angle from horizontal, the less solar radiation will enter the Deck Unit.

Note that this also reduces the solar charging capability. If a vessel is stationary for extended periods, this may result in insufficient maintenance charging. It is best suited for highly active vessels.

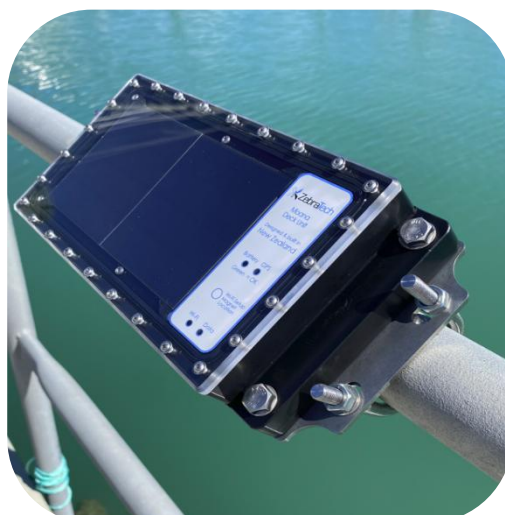

*Deck Unit mounted at 45 Degrees to minimise heating in hot climates*

Deck Unit serial number 5599 onwards, have an internal tilt sensor. The data is displayed in the Dashboard, so fleet managers can monitor the installed tilt angle of the Deck Unit. This is useful to confirm the mounted angle of the Deck Unit relative to the internal temperature.

### Heat Shield

In very hot climates, the ZebraTech heat shield can be used. This is a clear polycarbonate screen that can be easily attached to the Deck Unit. The shield reflects incoming Infra-Red wavelength that causes heating, whilst still allowing most visible light to pass through for solar generation.

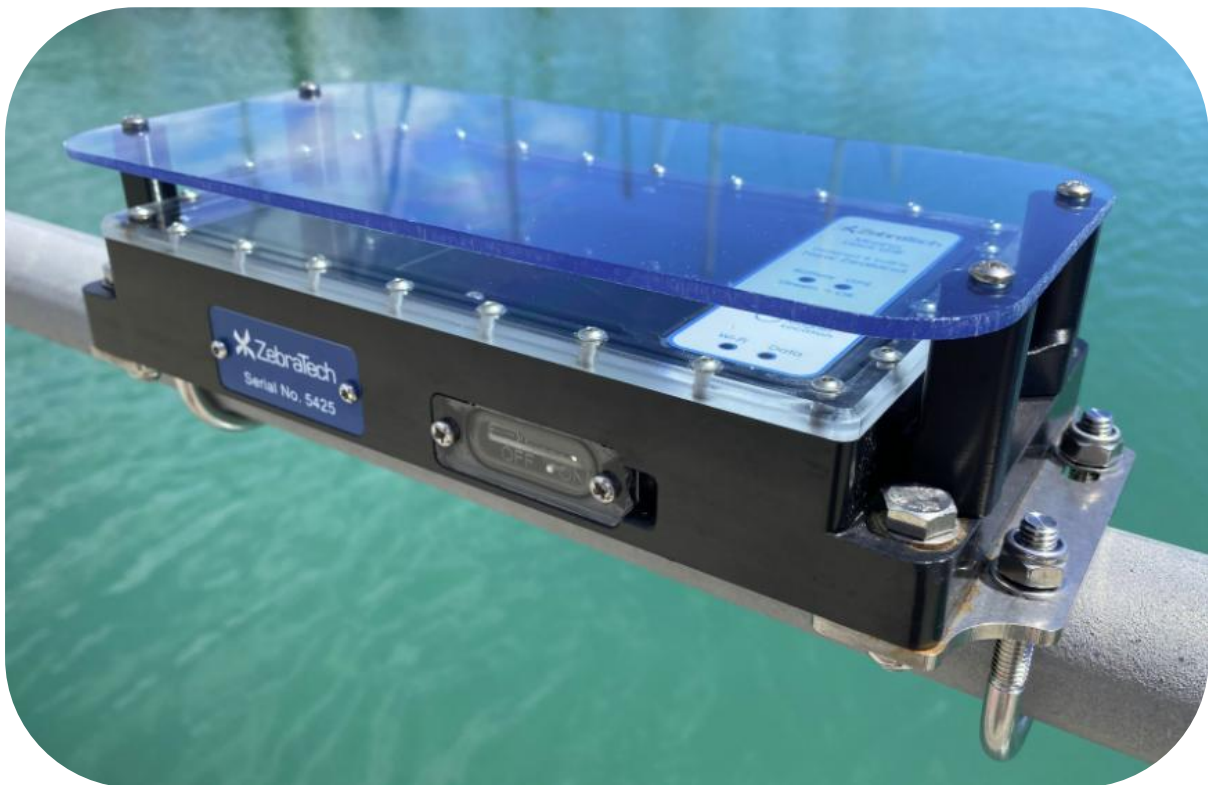

*Heat shield fitted to deck unit*

The Heat Shield is a simple to install option to reduce the heat build-up in Deck units operating in hot climates.

The heat shield attaches to the Deck Unit with 4 fasteners. The mounting holes for the fasteners have been factory drilled as standard in Deck Units from serial number 5499 onwards.

Earlier Deck units that are returned to ZebraTech for repair or servicing, are automatically drilled with the mounting holes.

## Heat Shield Kit

The heat shield is simple to install on site, requiring only a #2 Pozi driver for Deck Unit serial number 5499 onwards. A drill is required for earlier Deck Units.

The heat shield kit comprises of:

2 x Support pillars

4 x No.8 x 2.5" Pozi self-tapers A4 stainless steel fasteners

1 x Heat shield

## Installation

1. Check to determine if the Deck Unit has the mounting holes.



2. If the Deck Unit does not have the mounting holes (pre #5499), use a 3.2mm drill and the support pillars as drill guides to drill the 4 holes, 15mm deep

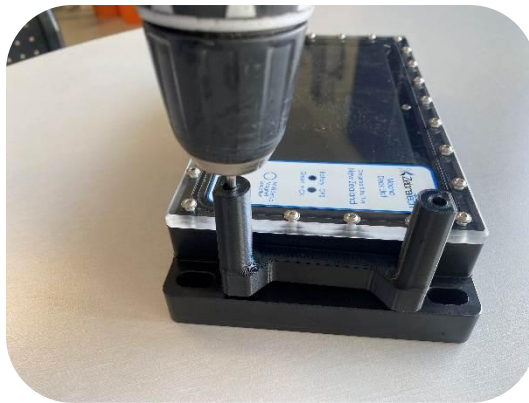

3. Place the pillars, heat shield and 4 screws into position
4. Using a #2 Pozi screwdriver, install the 4 screws. The screws must not be excessively tightened; When the underside of the screw head touches the heat shield, only apply  $\frac{1}{4}$  additional turn.

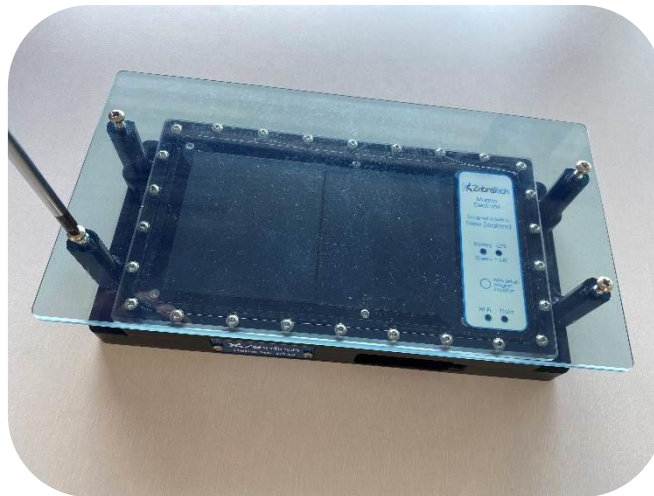

## Deck Unit Specifications

<b>Housing material</b>	High Density Polyethylene (HDPE), Acrylic
<b>Power supply</b>	
Internal battery	Serial number 5563 onwards Lithium-ion rigid shell Serial number 5213 to 5562 = 10 A/Hr Li-Po pouch Serial number 5000 to 5212 = 7 A/Hr Li-Po pouch
Battery endurance Emergency charging	Around 4 weeks with zero solar charge USB-C
<b>Sensors</b>	
GPS	15 second logging rate
Internal temperature	Daily minimum and maximum temperature reported in the 24-hour maintenance report
Bluetooth	Bluetooth LE for communicating with Moana TD
<b>Memory</b>	
Data storage	Non-volatile, 8 GB
<b>Communication options</b>	
Wi-Fi	2.4GHz. DHCP IP. User set SSID and password
Cellular	Hologram SIM optimised
<b>GPS variance</b>	
	Mean 5.5 meters
	Min 0.0 meters
	25% 2.3 meters
	50% 3.8 meters
	75% 6.3 meters
	95% 15.4 meters

## Revisions

There have been several significant hardware and firmware enhancements introduced into the Deck Unit at various times.

### Hardware revisions

Feature	Deck Unit serial number hardware feature introduced
Solar charging thermal control	5413
External permanently sealed on-off switch	5466
External circular power switch	5494
Circular SIM cap	5545
Heat shield mounting threaded holes	5499
Tilt sensor	5599
18650 battery pack	5563

#### *Significant hardware revisions*

### Firmware revisions

From time-to-time ZebraTech releases new firmware for the Deck Unit. When released, the Deck Units remotely download and install the new firmware automatically over cell or Wi-Fi, without interfering with operations.

Firmware version	New features and functions introduced
5.21	Temperature dependent solar charge (hardware dependent)
5.26	External power switch (Hardware dependent) Wi-Fi and cell communication priority function Cellular APN setting Wi-Fi password extended character set (Hardware dependent)
5.28	Direct communication functionality with Ocean Monitor App
5.31	Limit battery charging to 0-60 DegC (Hardware dependent)
5.36	Low temperature solar charging locked out at -4 DegC, restarts at -2.5DegC (Hardware dependent) Remove battery charge status dependency of port mode Port mode not active for 2 hours after cold start power-on

#### *Significant firmware features and functions*

## Cellular setup

If the Deck Unit is to be operated on the cellular network, ensure an active SIM card is installed.

**Always turn off the Deck Unit before installing a SIM card**

Use only a Micro SIM format

Ensure the SIM has been activated, and it is not pin (password) protected



## SIM card slot

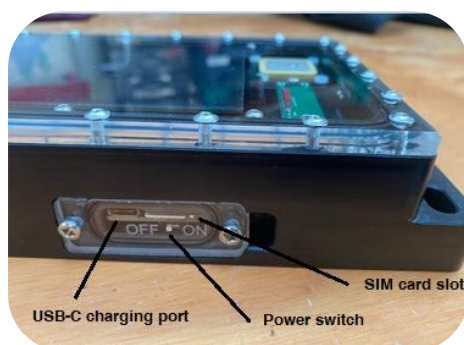

*Rectangular SIM slot cover plate (Up to serial number 5545)*

### 1) Clear rectangular cover plate

#### Removal

1. Carefully unscrew the 2 fasteners
2. Remove the cover plate and the O ring
3. Take care not to scratch or damage the inside surface of the cover plate as this is a sealing surface

Install the SIM card as per the instructions below

#### Re-install

1. Using a lint free clean tissue, clean the O ring groove, O ring, and inside surface of the side panel
2. Lightly grease the O ring with appropriate Silicone O ring grease
3. Install the O ring in the O ring groove
4. Place the cover plate onto position, ensuring the O ring is still sitting in the groove.
5. Install the 2 fasteners, tightening them alternatively at ½ turn
6. Do not overtighten the screws

7. Check the O ring has good continuous contact with the cover plate

## 2) Circular SIM cap



*Round port SIM slot and USB charging port (Serial number 5546 onwards)*

### Removal

1. Using a coin, or large screwdriver, unscrew the circular SIM cap  
Install the SIM card as per the instructions below

### Re-install

1. Clean and inspect the O ring on the cap. If it is clean and in good condition, lightly grease the O ring
2. Clean and inspect the O ring seat in the Deck Unit housing. If it is clean, apply a light finger wipe of grease
3. Replace the cap, do
- 4.

### SIM install

1. Clean the gold contacts with a tissue, taking care not to touch the contacts with your fingers
2. With the gold contacts on the underside, gently insert the SIM into the slot, with the angle cut corner on the leading edge
3. There should only be a light smooth spring resistance felt as the SIM is pressed into the slot
4. When the SIM is fully installed into the slot, there should be a small audible click
5. When insertion pressure is released, the SIM should be retained fully in the slot, flush with the carrier board
6. If the SIM cannot be fully inserted, or feels tight with strong resistance, remove the SIM, check it is correctly orientated, and then retry
7. Once the SIM is installed correctly, re-install the cover plate

## Hologram SIM setup

The Deck Unit has been optimised to use Hologram SIM. ZebraTech highly recommends the use of Hologram SIM. They eliminate any setup and offer the most reliable connectivity method. Hologram SIM cards operate in most countries around the world. They can often use multiple networks within a country and so provide blanket coverage.

Hologram SIM are available from ZebraTech, or can be ordered from Hologram <https://www.hologram.io/>

Once a hologram SIM is installed, no further setup is required. The Deck Unit can be switched on, and provided the unit has good cellular coverage, should transmit data to the cloud database.

## Non-Hologram SIM setup

Although the Deck Unit has been optimised for Hologram SIM, Deck Units with serial number 5466 onwards can use SIM cards from other cellular network providers. The cellular network APN (Access Point Name) associated with other SIM needs to be loaded into the Deck Unit

**Note: The APN for Twilio and Hologram SIM are automatically set by the Deck Unit and so do not need to be manually set. Just load the cell and switch on.**

## APN setting

Setting up the APN on the Deck unit requires a strong magnet and a Wi-Fi capable mobile phone, tablet or PC

1. Ensure the SIM card has been activated with a data plan, and has the password protection disabled
2. Instal the Sim card, and switch the Deck Unit on
3. Obtain the APN for the cellular network. This should be provided with the SIM card or contact the SIM network provider for details.
4. Hold a strong magnet on the “Magnet location” circle. Remove the magnet when the orange LED is continuously illuminated. The Deck Unit is now operating as a local Wi-Fi server
5. Open the Wi-Fi network selection page on the device, and select the “MoanaLogger” network



6. Once connected, open a web browser, and navigate to <http://192.168.4.1>
7. A new window should open, allowing the APN to be entered

11:06 4G 85

ZebraTech Moana Logger configuration

Please enter the SSID and password for your Wi-Fi network

SSID  
Moana

Password

Submit

Please enter the APN for your cellular network

APN  
hologram

Submit

8. Enter the exact APN associated with the cellular network into the text box and press the submit button
9. The Orange LED will flash whilst the Deck Unit tests the cellular connection.
10. If the test is successful, the battery and GPS LED will flash green
11. If the test is unsuccessful, the battery and GPS LED will flash red

## Cellular Setup Trouble shooting

1. Ensure the APN is correct for the cellular network that matches the SIM card. The APN is generally listed on the cellular network web site.
2. Check that the APN entered is correct. The APN is case sensitive, and ensure there is no space character at the end of the APN as this will prevent the Deck Unit from connecting to the cell network
3. Make sure the SIM is activated. If possible, install the SIM into a mobile phone or other device to check it can connect to the cell network.
4. If the SIM has been password protected, the Deck Unit will not be able to connect to the network.
5. Ensure the SIM has been properly installed, and the gold contacts are clean, dry, free from corrosion and grease free.
6. Always open a new web browser and navigate to <http://192.168.4.1> with each attempt. Do not “go back” and re-use the previous web page. This can introduce errors
7. The Deck Unit does not retain multiple APN settings for multiple SIM cards. If SIM cards are swapped, always follow the instructions above to ensure the correct APN is configured for each SIM

## Wi-Fi setup

Wi-Fi capable Deck Unit can use a local Wi-Fi network to send data to the cloud server.

**Note: The Deck Unit only currently operates on 2.4GHz Wi-Fi networks.**

The Deck Unit needs to have the Wi-Fi network name (SSID) and password credentials loaded correctly to access the local Wi-Fi network.

### Setting Wi-Fi credentials

Setting up the Deck Unit with the Wi-Fi network credentials requires a strong magnet and a Wi-Fi capable mobile phone, tablet or PC.

- 1) Place the strong magnet on the “Magnet location” circle until the orange LED is solidly illuminated
- 2) Open the Wi-Fi network selection page on the device, and select the “MoanaLogger” network



- 3) Once connected, open a web browser, and navigate to <http://192.168.4.1>
- 4) A screen should open that allows the Wi-Fi network name (SSID) and the password to be entered

11:06 4G 85

ZebraTech Moana Logger configuration

Please enter the SSID and password for your Wi-Fi network

SSID  
Moana

Password

Submit

Please enter the APN for your cellular network

APN  
Hologram

Submit

- 5) Once the SSID and password have been entered and the submit button pressed, the orange Wi-Fi flashes whilst the connection is tested
- 6) If the GPS and Battery LED flash green, the test is successful, and the Deck unit is able to connect to the Wi-Fi network and upload data
- 7) If the GPS and Battery LED flash Red, then the Deck Unit has been unable to connect to the Wi-Fi network

## Wi-Fi Trouble shooting

1. The Deck Unit will only operate on 2.4Ghz Wi-Fi networks, not 5Ghz
2. The SSID and passwords are both case sensitive and must be entered precisely. If the Wi-Fi connection test fails, repeat the steps above, making absolutely sure the SSID and password have been entered correctly to match the network
3. It may be necessary to whitelist the Deck Unit to allow access the internet through the Wi-Fi network. Consult your network IT administrator to check if this is required
4. If the SSID or password contains any of these characters / ? : @ & = + \$ \* # AND the Deck Unit serial number is prior to 5466, then the method listed above will not load the SSID or password correctly. Contact ZebraTech for support if this is required.
5. Check the Wi-Fi network signal strength is adequate. This can be done using a Wi-Fi signal strength app on a mobile device. Mount the Deck Unit in a location with a strong signal strength
6. Ensure that the signal strength is consistent. There have been instances where a vessel at port has open bulkhead doors. At sea, the doors are closed, which can reduce the Wi-Fi range, possibly resulting in loss of connectivity
7. The Deck Unit can only retain the SSID and password for the current Wi-Fi network. If the network is changed and then swapped back to the original, the credentials will need to be manually reloaded

### Starlink Maritime Wi-Fi

By default, Starlink only maintains a 5GHz Wi-Fi network. The Deck Unit requires a 2.4GHz network, so the Starlink router will need to be configured with an additional 2.4GHz network. It is advisable to use different SSID names for the 2.4GHz and 5GHz networks

Some operators have had connection and reliability issues using Deck Units on Starlink Wi-Fi networks. There are various explanations for this posted on the internet.

One reliable solution involves using a wireless Wi-Fi bridge or router, that connects to the Starlink 5Ghz Wi-Fi network and then hosts a separate 2.4GHz Wi-Fi network for the Deck Unit.

## Cell/Wi-Fi priority system

Deck Units with firmware version 5.26 and above have a Cell/Wi-Fi priority system. This system sets the Deck Unit to always try one communication method first. If that method fails, it will then attempt to communicate with the fall-back method.

Here are some examples where this system can be useful.

Wi-Fi priority cell fallback. A vessel has a Wi-Fi network, however this may be unreliable. Falling back to cellular during these times ensures continuity of connection.

Cell priority Wi-Fi fallback. When in cellular range, low-cost cellular data is used, avoiding usage of more expensive satellite data through the Wi-Fi network.

### Setup

The Cell/Wi-Fi priority system is set on the ZebraTech server. The Deck Units check the setting once every 24 hours. To change the priority, please email [sales@zebratech.co.nz](mailto:sales@zebratech.co.nz) providing the Deck Unit serial number, and the priority (Wi-Fi priority cell fall-back, OR Cell priority Wi-Fi fall-back).

Please allow several days for the implementation of the desired priority setting.

By default, Deck Units that have not had a priority setting, will always attempt to communicate using the cell network, provided a SIM is installed. If they don't have a SIM installed, they will communicate using Wi-Fi, provided credentials have been set.

## Deck Unit status LED



*Deck Unit status indicator panel*

### GPS LED indicator

GPS status LED	Description	Battery voltage
Green	GPS signal detected	3.4v to 4.2v
Red	No GPS signal detected	3.4v to 4.2v
Green	Full functionality maintained	>3.6v
Green	Battery low. No cell/Wi-Fi communications. Moana TD and GPS functionality maintained	3.4v to 3.6v
Red	Low battery shutdown. No cell/Wi-Fi communications, Moana TD or GPS functionality maintained	< 3.4v

- Data indicator blue flash = Unsent data awaiting transmission to the cloud server
- Data indicator blue solid = Connected to a Moana TD
- Orange comms indicator flash = Comms session active
- Orange comms indicator solid = Wi-Fi setup in progress

### Battery LED indicator table

Switched Off	State	Standard	Moon pool and external power versions
<b>No power-in</b>	Any	Red LED: off Green LED: off	Red LED: off Green LED: off
<b>USB power-in</b>	Fully charged	Red LED: off Green LED: solid	Red LED: off Green LED: solid
	Charging	Red LED: solid Green LED: off	Red LED: solid Green LED: off
	Not charging e.g. insufficient USB power	Red LED: 1 sec on / 1 sec off Green LED: off	Red LED: 1 sec on / 1 sec off Green LED: off
<b>External power-in</b>	Any	N/A	Red LED: off Green LED: off

Switched On	State	Standard	Moon pool
<b>No power-in</b>	Battery > 3.60V	Red LED: off Green LED: 50ms blink every 10 sec	Red LED: off Green LED: 50ms blink every 10 sec
	3.40V <= Battery < 3.60V (No comms)	Red LED: 50ms blink every 10 sec Green LED: 50ms blink every 10 sec	Red LED: 50ms blink every 10 sec Green LED: 50ms blink every 10 sec
	Battery < 3.40V (Hibernation)	Red LED: 50ms blink every 10 sec Green LED: off	Red LED: 50ms blink every 10 sec Green LED: off
<b>USB power-in</b>	Fully charged	Red LED: off Green LED: solid	Red LED: off Green LED: solid
	Charging	Red LED: solid Green LED: off	Red LED: solid Green LED: off
	Not charging e.g. insufficient USB power	Red LED: 1 sec on / 1 sec off Green LED: off	Red LED: 1 sec on / 1 sec off Green LED: off
<b>External power-in</b>	Fully charged or disabled due to voltage or temperature limit	N/A	Red LED: off Green LED: solid
	Charging	N/A	Red LED: solid Green LED: off
	Not charging e.g. external power insufficient	N/A	Red LED: 1 sec on / 1 sec off Green LED: off

Note: When Red and Green flash together, the colour appears orange

## USB charging port

The Deck Unit is fitted with an emergency USB-C charge port, located inside the rectangular or circular SIM cap.

Only use a USB-A 2.0 single port charger (white or grey USB socket), with a USB-C to USB-A cable.



The following devices may not charge the Deck Unit successfully:

- Computer USB port
- USB-C charger
- USB 3.0 charger

When charging, the battery LED will be solid red. When fully charged, it will turn solid green.

## Tracking Function

The Deck Unit has the capability to log the vessel position track to file, which is then periodically uploaded to the cloud server. This function is controlled remotely.

If you would like to enable this function, please contact ZebraTech with the serial number of the Deck Unit, the position log interval (30 seconds to 10 minutes), and the required file upload interval (1 hour to 1 week)

Please note that the tracking function is not intended to be used for compliance or regulatory purposes.

## Port Mode

### **Serial numbers 5302 and below**

Under normal operating conditions, the Deck Unit receives and stores its GPS location every 15 seconds. If, however, the vessel is stationary for 1 hour (i.e. its average GPS location from the last 6 readings remains within a 50-meter radius from its starting location), the Deck Unit will enter Port Mode. The vessel's average GPS location is now its port position.

To conserve battery power during Port Mode, the GPS and Bluetooth scanning rates are reduced. The GPS location is received and stored once every 5 minutes and Bluetooth is scanned for 40 seconds every 5 minutes. If a Moana sensor surfaces while the Deck Unit is in Port Mode, it may take up to 5 minutes for the sensor data to be offloaded. Moana sensor data files may not have location data for a given sample, if the Deck Unit has not stored a GPS location within 60 seconds of the sample time stamp.

If during Port Mode, the vessel's instantaneous GPS location deviates more than 50 meters from its port position, the Deck Unit temporarily exits Port Mode and the GPS and Bluetooth scanning rates are restored to normal. Once 6 GPS location readings have been received, or 2 minutes have elapsed, the updated average vessel location is compared to the port position. If the average vessel position has deviated from the port position by more than 50 meters, the exit from Port mode is confirmed and the 1-hour stationary vessel timer is reset. Otherwise, the Deck Unit will return to Port Mode and the GPS and Bluetooth scanning rates will again be reduced.

### **Serial numbers 5303 and above, firmware 5.35 and below**

Under normal operating conditions, the Deck Unit receives and stores its GPS location every 10 seconds, and it is not allowed to enter Port Mode. However, if the battery voltage drops 10% below its target, the Deck Unit is allowed to enter Port Mode and operate as per the description for serial numbers 5302 and below.

If the battery voltage rises above its target, the Deck Unit will exit Port Mode immediately and resume normal operation.

Port Mode is factory enabled by default. However, there may be circumstances where it is not desirable. For example, a fishing operation whereby the vessel is stationary for at least 1 hour before moving and lifting a Moana TD before the Port Mode has been exited, the lift position may not be accurately assigned, and there may be a delay before the Deck Unit connects with the Moana TD.

**Port mode firmware version above 5.35**

Port mode will not activate for 2 hours after a cold start

After 2 hours, port mode will activate if the above stationary conditions are met, regardless of the battery charge state.

Port mode is controlled remotely by ZebraTech. Please contact ZebraTech with the serial number of the Deck Unit, and the desired Port Mode setting (on or off).

## Thermal responsive charging control

Aging of the Deck Unit internal battery increases when it is fully charged and exposed to high temperatures.

To avoid maintaining a highly charged battery in hot climates, the Deck Unit operates a temperature dependent charging control system, based on the maximum internal temperature during the previous 14 days.

Note that port mode is an optional configuration and is not operative by default. The battery charge dependent operation of port mode is only a feature of some firmware versions. See “Revision” section for details.

Maximum daily temperature over the past 14 days	20	25	30	35	40	45	50	55	60	65	70
Solar charger disabled above this battery voltage	4.20	4.17	4.13	4.08	4.02	3.95	3.87	3.85	3.83	3.82	3.80
Solar charger enabled below this battery voltage	4.15	4.13	4.09	4.02	3.98	3.91	3.85	3.84	3.81	3.80	3.79
Port mode disabled above this voltage	4.08	4.04	4.00	3.95	3.91	3.85	3.82	3.80	3.78	3.77	3.75
Port mode enabled below this battery voltage											

*Table of the battery voltages used to disable/enable solar charging and port mode*

Note that the same threshold is used to both enable solar charging and disable port mode.

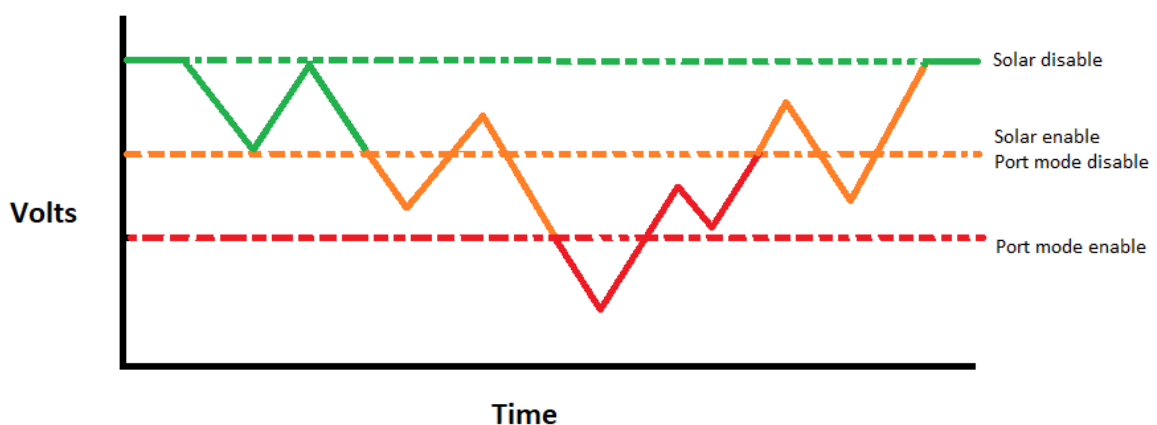

Green: Solar charger disabled. port mode disabled.

Orange: Solar charger enabled; port mode disabled.

Red: Solar charger enabled; port mode enabled.

### Low temperature charging control

To avoid possible damage to the internal battery, firmware 5.37 and onwards, halts solar charging below -4 DegC, and restarts solar charging as the temperature rises above -2 DegC.

## Data Format

The structure of the data files delivered from the ZebraTech server to the end point is CSV format.

Example data file from Moana TD200. Note; The header may vary according to the firmware version:

```
Deck unit serial number,5107
Deck unit firmware version,5.24
Deck unit battery voltage,4.19
Deck unit battery percent,98.9
Upload position,-36.799458,+174.944940
Upload signal strength,0
Upload attempts,1
Upload time,20250226T171327
Upload stats,0,0
Depth rating (m),200
Download position,-36.799478,+174.944958
Download Time,26/02/2025 17:12:45
Moana Serial Number,701
Moana Firmware,MOANA-2.00
Protocol Version,2
Moana calibration date,28/02/2023
Reset Codes, 0x100104
Moana Battery (V),3.46
Max Lifetime Depth (dBar),50.5
Baseline(mBar),931
DateTime (UTC),Lat,Lon,Depth Decibar,Temperature C
20250226T170853,-36.799501,+174.944861,1.6,22.741
20250226T170858,-36.799488,+174.944911,2.7,22.737
20250226T170901,-36.799488,+174.944911,3.9,22.738
20250226T170909,-36.799488,+174.944911,7.0,22.743
20250226T170916,-36.799493,+174.944878,8.3,22.733
20250226T170918,-36.799493,+174.944878,9.4,22.734
20250226T170921,-36.799493,+174.944878,10.7,22.744
20250226T170924,-36.799491,+174.944888,11.9,22.754
20250226T170929,-36.799491,+174.944888,10.9,22.748
20250226T171109,-36.799505,+174.944908,12.2,22.751
20250226T171219,-36.799511,+174.944960,11.0,22.737
20250226T171221,-36.799511,+174.944960,10.0,22.737
20250226T171224,-36.799443,+174.945006,8.4,22.741
20250226T171225,-36.799443,+174.945006,7.4,22.742
20250226T171227,-36.799443,+174.945006,5.9,22.739
20250226T171229,-36.799443,+174.945006,4.5,22.738
20250226T171231,-36.799443,+174.945006,3.0,22.738
20250226T171234,-36.799443,+174.945006,0.8,22.757
20250226T171237,-36.799443,+174.945006,-0.1,22.495
```

END

Depth: Depth units are Decibar, referenced to the pressure of the sea surface at the start of the dive event

Temperature: Degree Centigrade

Position: Degrees, decimal degrees

Time and date: UTC

Reset code: Status information, useful for diagnostic purposes by ZebraTech

Bits	28-31	24-27	20-23	16-19	12-15	8-11	4-7	0-3
Nibble	7	6	5	4	3	2	1	0
0x	Temperature ADC registers reconfigured	Pressure ADC registers reconfigured	Power on reset	Brown out detected 1.2V	Brown out detected 3.3V	External reset	Watchdog reset	System reset

Baseline (mBar): Ambient atmospheric sea level pressure measured prior to the start of the dive event

Moana Battery Volts: This should be above 3 volts

Deck Unit Battery Voltage: Low = 3.6 volts Full = 4.2 volts

## Data delivery

Data received by the ZebraTech cloud server can be delivered to the customer endpoint by; FTP, AWS S3 or email. Please contact ZebraTech to discuss your preferred delivery method.

## External power version

The external power version Deck Unit features a connector on the outside of the housing. This can be used to provide the Deck Unit with periodic in-situ power for top-up charging from a USB power bank, or permanent hard-wired power.



*External power connector*

### USB power bank

The external power Deck Unit version can be charged from a USB power bank. ZebraTech can supply a USB power cable for the Nestout Outdoor power bank (<https://nestout.com/products/outdoor-portable-battery-15000mah>)

A fully charged 15000mAh power bank will charge\* a Deck Unit in 21 hours, providing up to 4 weeks of Deck Unit operation in complete absence of solar charging.

\*Note: A fully charged 15000mAh power bank may not necessarily fully charge a flat Deck Unit. It depends on the temperature, and condition of the power bank.



*External power version Deck Unit charging from power bank*

Please follow the Nestout power bank operating instructions.

### **External power supply**

The external power connector can be connected to a permanent or semi-permanent power supply. In this instance, the Deck Unit reduces the charge status of the internal battery, so it is not maintained at full charge and operates as a backup battery to cover power outages.

It is recommended that an inline fuse is fitted with the power supply.

### **Connector specifications**

Power supply: 5 to 24 volt DC 2.5 Watt

1 Amp fuse recommended

Cable end connector: Amphenol Standard Circular Connector C16-M CIRCULAR ECOMATE, part number: C016 20 0003 110 12

Pin 1 Power +V

Pin 4 Power ground

### **Status LED**

Refer to the Battery LED indicator table for interpretation of the Battery LED

## Moonpool version

The Moonpool Deck unit is a version that requires both external power supply and GPS data. It is intended to be installed on vessels where the Moana sensors enter the vessel internally, and so the deck unit must be installed below deck, without sky view for GPS signal and solar charging. The Moonpool version has an internal battery for backup power when the primary supply fails.



*Moon Pool Deck Unit with external cable connected*



*Moon pool Deck Unit external power connector with protective cap fitted*

### **GPS data**

Unlike the standard Deck Unit, the Moon Pool version does not have an internal GPS receiver. It requires GPS data to be provided through the external connector. The data protocol requirements are:

- NMEA 0183
- RS 422
- RMC sentence required, other sentences ignored
- 10 second update rate

### **Power supply**

The Moon Pool Deck Unit has an internal battery for backup but requires a 5 to 24 volt DC external power supply, rated to 2.5 Watts. A 1 Amp series fuse is recommended

### **Connector**

The cable end connector: Amphenol Standard Circular Connector C16-M CIRCULAR ECOMATE part number: C016 20 0003 110 12

Hookup

Pin 1 Power +V

Pin 2 GPS data A

Pin 3 GPS data B

Pin 4 Power ground

### **Status LED**

Refer to the Battery LED indicator table for interpretation of the Battery LED

# Dashboard

ZebraTech has developed a powerful on-line Dashboard that visualises the location and operating status of Moana TD and Deck Units, with a wide variety of alarm conditions. This simplifies the task of monitoring and managing Moana and Deck Unit fleets.

Access to the Dashboard can be provided to vessel fleet managers, to assist with the operation of multiple Moana networks. Please contact ZebraTech to discuss the Dashboard and how it can assist your operations.

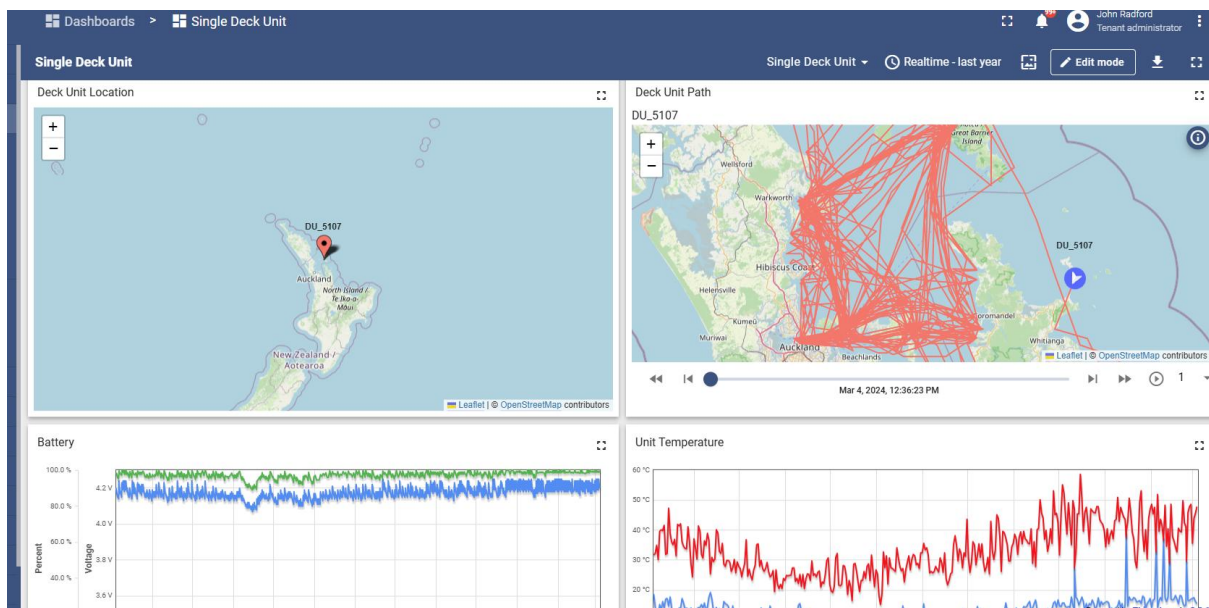

*ZebraTech Dashboard*

## ZebraTech BLE app

“ZebraTech BLE” is free to download from the Google Play store, and App Store.

The app can be used to connect using Bluetooth, and offload data from a Moana TD sensor after they have been deployed. The geographical position at time of offload is recorded in the data file header. The data file can then be shared or viewed.

The app can be operated in a manual scan mode, or Auto-Offload Mode. In Auto Offload mode the app constantly scans for Moana TD sensors. If one is detected, the data is offloaded and then scanning resumes.

The app is useful for testing Moana TD in the absence of a Deck Unit. The app is not recommended as the basis of an onboard data collection program.



## Maintenance and calibration

If the Moana TD is to be stored, it should be washed in clean fresh water and dried before storage.

Moana TD does not have any user serviceable parts. Disassembly can result in damage. Please contact ZebraTech for advice regarding operation and maintenance.

The calibration interval and battery life of Moana TD is 2 years from the calibration date as specified in the data file. Please return your Moana TD to ZebraTech when the calibration and battery change are due.

The Deck Unit also does not have any serviceable parts. It is important to keep the solar panel clean.

## Further Assistance

For further assistance with this or any other **ZebraTech** product, please contact:

**ZebraTech Ltd**  
**PO Box 1668**  
**Nelson 7040**  
**New Zealand**

**Tel: International 0064 3 548 0468**

Email: [sales@zebratech.co.nz](mailto:sales@zebratech.co.nz)

For up-to-date information about ZebraTech products, please visit the **ZebraTech** website at:

<http://www.ZebraTech.co.nz>

ZebraTech products are proudly designed and manufactured in New Zealand

